

# Lock Block Construction

The plane of the seat rails is the foundation of chair strength. The Lock Block construction holds this seat plane stable even under extreme stress – thereby making the entire chair exponentially stronger.

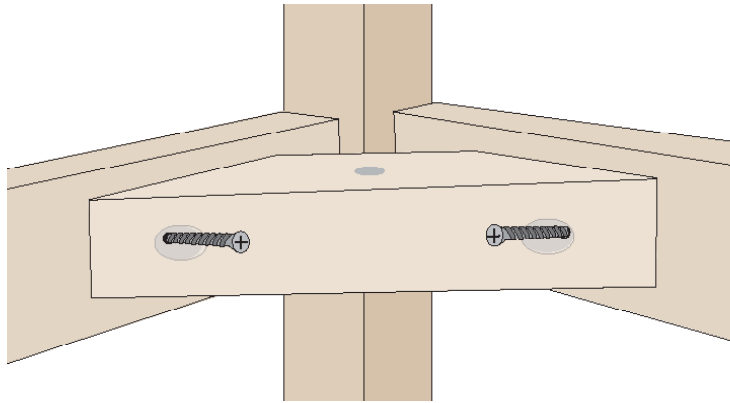

Standard Corner Block

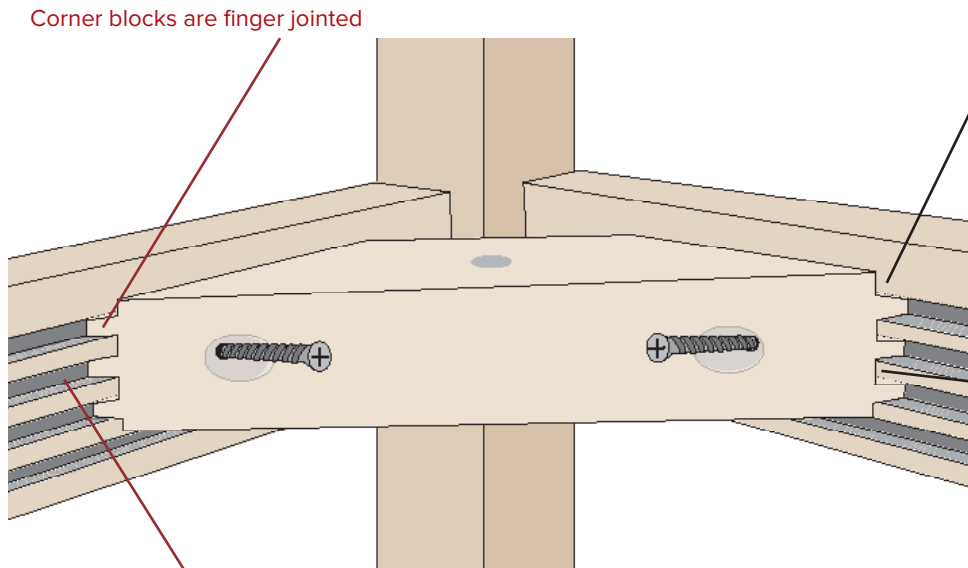

Corner blocks are finger jointed

Locking Corner Block

Seat rails are precision machined to match the corner block finger joint.

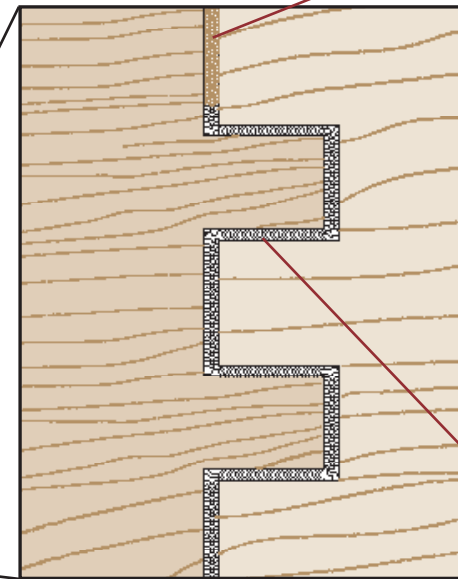

Glue

This allows for a "side grain to side grain" wood connection – the strongest type of wood adhesion.

Side grain to side grain

Lock blocks more than double the glue bond surface. As with standard blocks, screws add additional support. The seat frame will not flex out of its intended shape and transfer stress to other points of the chair.